

WP1160

Issued: 5/98

Fiber Selection Guide for Premises Networks

David M. Bean
Premises Project Manager

Table of Contents

- Introduction
- Attenuation & Bandwidth
- Fiber Options
- Maximum Link Lengths & Data Rates
- Bending Capability
- Tensile Strength
- Fiber Coatings
- Fiber Compatibility
- Component & System Cost
- Standards Coverage
- Specifying Optical Fiber
- Summary

WP1160

Issued: 5/98

**Fiber Selection Guide
for Premises Networks****David M. Bean**
Premises Project Manager**Introduction**

All optical fibers are not alike. There are several major types, which are made differently, have different characteristics, operate in different ways, and are suitable for certain applications. Some differences that seem subtle can lead to large functional differences that can directly affect the current and long-term operation of the network. For this reason, it is important that network designers and end-users understand the available fiber choices.

The two major classifications of fiber are: multimode and single-mode. In general, multimode fiber is best suited for premises applications where links are less than 2000 meters and there are many connectors. The larger core diameter of multimode fiber allows the use of relatively inexpensive LED (Light Emitting Diode) and VCSEL (Vertical Cavity Surface Emitting Laser) transmitters and low-cost connectors. Single-mode fiber is best suited for long distance applications (greater than 1-2 kilometers), but requires higher cost connectors and transceivers.

Attenuation & Bandwidth

Before comparing the specific fibers, it is first important to understand the two primary optical fiber attributes: attenuation and bandwidth.

Attenuation is a reduction of signal magnitude, or loss, as light travels through a fiber. Fiber attenuation is measured in decibels per kilometer (dB/km). A higher attenuation number means more loss and poorer performance.

Fiber bandwidth quantifies the information carrying capacity of a fiber. Bandwidth is measured in units of MHz•km. This value refers to the capacity of the fiber which in turn determines the maximum link distances depending on the baud rate or application protocol speed.

While the actual formula is more complex, the following statement illustrates the point in concept. The bandwidth value for a fiber (in MHz•km) is a constant. As the data rate (measured in MHz) increases to gigabit speeds, the distance (km) decreases. In short, the benefits of higher bandwidth as measured in MHz•km are:

1. Longer link lengths (at a given protocol speed)
2. Higher data rates (at a given link length)
3. A combination of #1 and #2.

Fiber Options

Specifically, there are three fiber product options for premises networks:

- 50/125 μm multimode fiber
- 62.5/125 μm multimode fiber
- Single-mode fiber (SMF)

The numeric notation (e.g. 50/125 μm) signifies the size of the glass core where the light travels (50 μm) and the outside glass cladding diameter (125 μm). This common cladding diameter provides nearly identical mechanical properties for the three fibers.

Table 1: Fiber Options

	Dimensions	Refractive Index Profile (Typical)	Spectral Attenuation	Bandwidth (MHz•km)*
50/125 μm Multimode				
62.5/125 μm Multimode				
SMF Single-mode				Virtually Unlimited Modal Bandwidth

*Standard bandwidths are shown. Other multimode bandwidths are available. We've simplified cabler contract pricing to eliminate all these other cells.

Their optical properties, however, vary significantly. The refractive index of each product is precisely designed to channel light down the fiber with certain characteristics such as bandwidth and attenuation. Table 1 outlines the fundamental physical and optical differences between fibers.

Multimode fiber uses a graded (i.e. parabolic in shape) index to minimize modal dispersion. This design maximizes bandwidth while maintaining low attenuation characteristics. For multimode fibers, bandwidth is the major limiting factor in network design. For this reason, network designers are now considering 50 μm fiber because of its distinct 3X bandwidth advantage over 62.5 μm fiber in the 850 nm window (i.e. 500 versus 160 MHz•km).

Single-mode fiber is designed to carry only one mode of light, and thus does not experience modal dispersion like multimode fiber. For this reason, single-mode fiber is not limited by bandwidth, but by attenuation and system cost issues.

Maximum Link Lengths & Data Rates

Although fiber bandwidth is a critical factor in determining link length and data rate, it is not the only one. Transmitter and receiver characteristics are as important as bandwidth in determining possible link length and data rates. Ultimately, the

maximum length for a fiber link (i.e. the maximum distance from source to receiver) is determined primarily by:

- Transmitter rise time (ns)
- Transmitter spectral width
- Receiver rise time (ns)
- Protocol baud rate (MBaud/s)
- Fiber bandwidth (MHz•km)

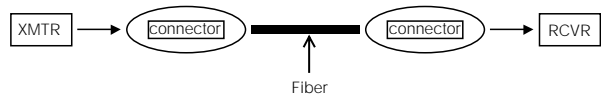

Figure 1: Communication Link

Since most protocols specify the transmitter and receiver rise times, we can simplify this relationship. A simplified model can determine link length from fiber bandwidth and protocol speed. This simplified relationship is shown in Figure 2.

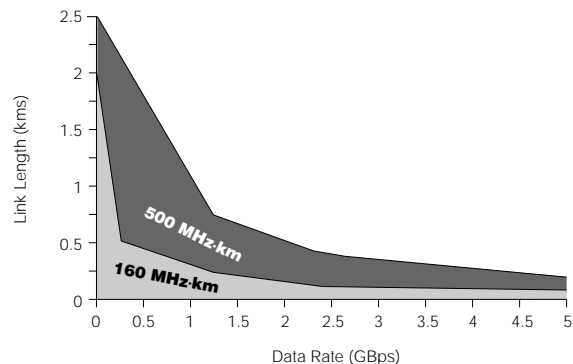

Figure 2: Bandwidth, Data Rate & Link Length

Using this graph, we can estimate the maximum link length for a given data rate. For example, the maximum link lengths for a fiber of 500 MHz•km bandwidth is over 500 meters at Gigabit Ethernet speeds. Similarly, 160 MHz•km bandwidth will yield approximately 220 meters. Alternately, for a given protocol speed and link length, the required bandwidth can be estimated. Or, for a given bandwidth and link length, the maximum protocol speed can be estimated.

Bending Capability

Contrary to popular belief, optical fiber is very flexible and capable of relatively tight bending conditions (as illustrated in Figure 3). From a long-term mechanical standpoint, TIA 568-A allows for a 30 mm bend radius (1.18 inches) for two and four fiber cables. Some cable manufacturers specify a long-term bend radius that exceed this standard, and is as low as a 1.0 inch bend radius.

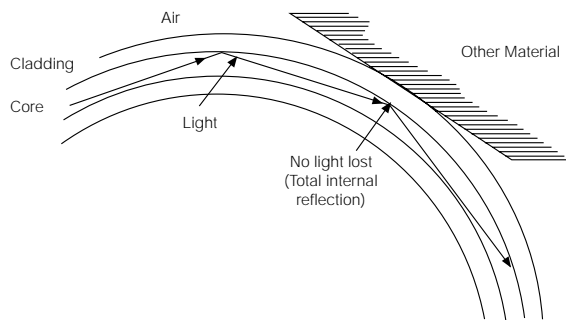

Figure 3: Fiber Is Capable of Channeling Light Through Relatively Tight Bends

Since all premises fibers maintain the same glass cladding diameter, they all have the same bending flexibility. From an optical standpoint, bending affects attenuation loss only at very small bend diameters (less than 20 mm or -1 inch).

Comparison of 50 and 62.5 μm Multimode Fiber Bend Loss using FOTP 62 Method A with Launch Procedure B of FOTP 50

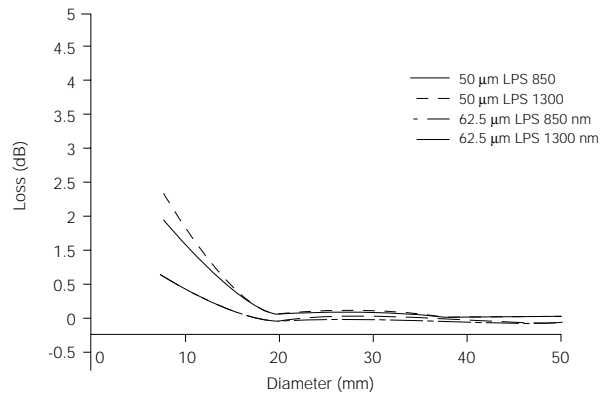

Figure 4: Bending Performance

For example, a one-inch bend diameter (25.4 mm) will experience virtually the same attenuation loss for all multimode fibers as shown in Figure 4. Bending also has a minimal effect on bandwidth performance.

Tensile Strength

Although 50 μm and SMF have smaller core diameters than 62.5 μm, all fibers have virtually identical tensile strength properties. For example, 50 μm fiber has a smaller glass core diameter of 50 microns, but the same glass cladding diameter of 125 μm when compared to 62.5 μm fiber. With the same outer diameter, all fibers maintain the same physical strength as well as the same handling properties.

Fiber Coatings

The fiber coating protects the fiber from external mechanical and environmental damage. The coating also facilitates the coloring and cabling processes. Thus, the fiber coating maintains the strength and handleability of the optical fiber. Fiber coating consists of 2 layers, an inner primary coating and an outer primary coating, as illustrated in Figure 5.

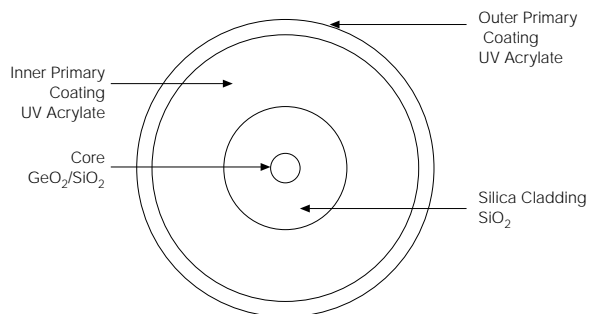

Figure 5: Fiber Structure

In general, fiber manufacturers use the same coating design for 50 μm , 62.5 μm , and SMF.

Fiber Compatibility

It is important to understand fiber compatibility, especially if different fiber types will be used in a given location. In short, 50/125 μm fiber is compatible with 62.5/125 μm fiber in all applications environments using either LED or laser sources. SMF fiber is *not* compatible with either 50 μm or 62.5 μm multimode fibers.

Corning performed extensive physical tests and computer simulations on 50 μm and 62.5 μm fiber to confirm that both multimode fibers are completely interchangeable.

Initially, worst-case laser sources were tested for mixed fiber coupling losses (62.5 μm into 50 μm and vice versa). Tests found no significant coupling losses, which indicates that 50 μm and 62.5 μm fiber are fully compatible with laser sources as shown in Figure 6. This result was no surprise since lasers have a relatively small spot size that launches light into the center of the fiber.

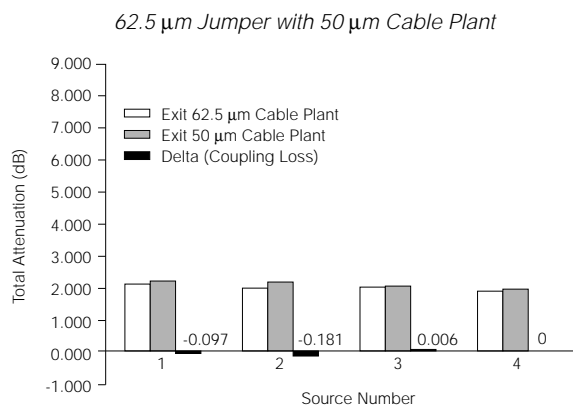

Figure 6: Laser Coupling Losses

Next, LED sources were tested with 50 μm and 62.5 μm mixed media cable plants. As illustrated in Figure 7, no failures were found in 1300 nm LED systems after 20,000 trials were simulated.

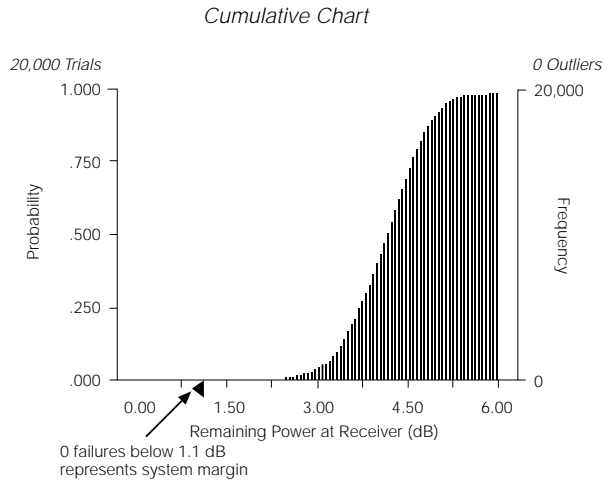

Figure 7: 1300 nm LED Systems - Remaining Power in a Mixed 50/62.5 μm System

In addition, 20,000 trials of 850 nm LEDs showed similar results.

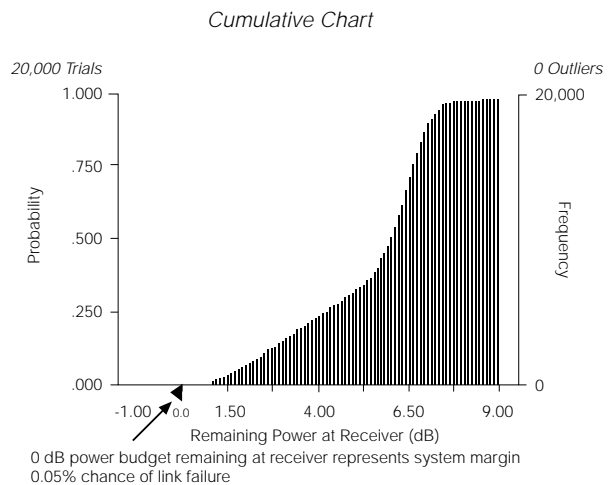

Figure 8: 850 nm LED Systems - Remaining Power in a Mixed 50/62.5 μm System

A *one-time* attenuation loss is experienced when coupling 62.5 μm fiber into 50 μm fiber with LEDs, but, as shown in Figures 7 and 8, this loss is easily covered by the excess power loss budget of the system. This one-time power loss is independent of the number of connectors and fiber type changes that occur in a cable run.

Component & System Cost

Network design is often driven as much by system cost as it is by system performance. Fiber choice is increasingly more important as component costs continue to drop and system performance requirements increase. In other words, low-cost, high performance electronics will quickly require greater bandwidth and operating performance of the installed cabling systems. Thus, it is strongly recommended that fiber be chosen carefully so that it economically meets all reasonable current and future needs.

Figure 9 outlines the relative costs of multimode system components.

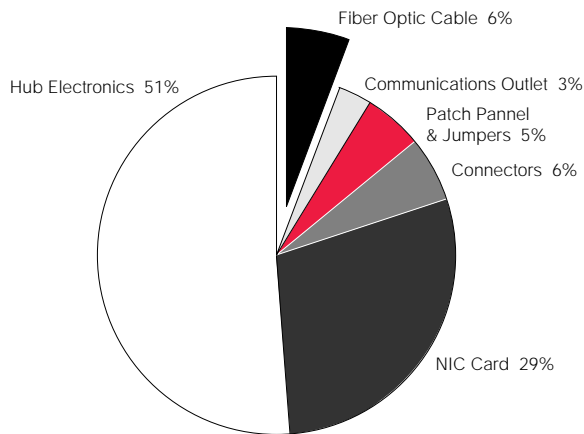

Figure 9: Relative Components Cost (1998 Corning Estimates)

50 μm and 62.5 μm multimode systems use the same connectors, transceivers, and cable constructions. 50 μm and 62.5 μm fibers also have similar price points within the fiber industry. Consequently, both 50 μm and 62.5 μm system costs are virtually identical. Single-mode systems, however, use more expensive transceivers and connectors that drive costs up considerably. By comparison, SMF systems are roughly 4X the cost of multimode systems.

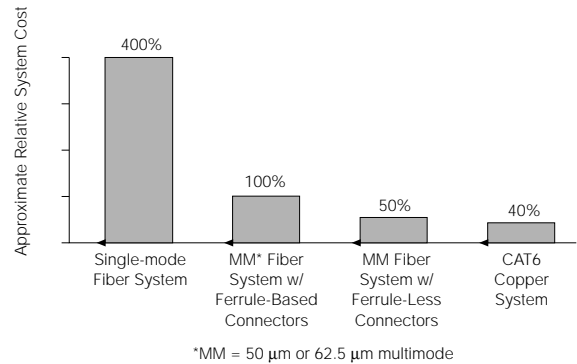

Figure 10: Relative System Per Seat Costs (1998 Corning Estimates)

Standards Coverage

50 μm , 62.5 μm , and SMF are covered in all major fiber, cable, and applications standards as outlined in the following tables.

Table 2: Fiber & Cable Standards

Std Type	Coverage	Standard Name	- Specific Standard -		
			50 μm	62.5 μm	SMF
Fiber	N. America	Detail Specification for Optical Fiber	ANS/TIA 492AAAB	ANS/TIA 492AAAA	ANS/TIA 492CAAA
	International	Product Specification for Optical Fiber	IEC 793-2:1992	IEC 793-2:1992	IEC 793-2:1992
Cable	N. America	Commercial Bld. Telecom. Cabling Std.	ANS/TIA/EIA 568-A*	ANS/TIA/EIA 568-A	ANS/TIA/EIA 568-A
	International	Generic Cabling for Customer Premises	IS 11801	IS 11801	IS 11801

*Accepted by TR-41.8 working group. To be included in next draft of TIA 568.

Table 3: Applications Standards

Application	Data Rate (Mb/sec)	Wavelength (nm)	BW (MHz•km)		Max. Length (meters)		
			50 µm	62.5 µm	50 µm	62.5 µm	SMF
Ethernet - 10BaseF	10	850	500*	160	1000*	2000	—
Ethernet - 100BaseF	100	1300	500*	500	2000	2000	2000
Ethernet - 1000Base-SX	1000	850	500†	160†	550	220	—
Ethernet - 1000Base-LX	1000	1300	500†	500	550	550	5000
Token Ring	16	850	500*	160	1000*	2000	—
FDDI PMD	100	1300 MMF	500*	500	2000*	2000	—
FDDI-LCF	100	1300 MMF	500*	500	500*	500	—
FDDI-SMF	100	1300 SMF	—	—	—	—	58000
Fibre Channel	1063	780/850	500	160	500	175	—
Fibre Channel	531	780/850	500	160	1500	350	—
Fibre Channel	531 & 1063	1300 SMF	—	—	—	—	10000
ATM	155	780/850	500ç	160	2000ç	2000	—
ATM	155	1300	500	500	2000	2000	55000
ATM	622	1300 LED	500	500	500	500	—
ATM	622	780/850	500ç	160	500ç	500	—
ATM	622	1300 SMF	—	—	—	—	15000

* Addressed in informative annex of the standard

† Additional specified bandwidth options are 50 µm 400/400 MHz•km and 62.5 µm 200/500 Mz•km

ç Using an uncommon 50 µm BW of 160 MHz•km, the link lengths would be 1,000 and 300 meters for 155 and 622 Mb/s respectively

Specifying Optical Fiber

In specifying your voice/data communications network, optical fiber should not be considered “just another component.” As the pathway for your communications network, fiber is a primary determinant of system performance.

Your cable supplier will see to it that you get fiber capable of meeting the specifications in your request for quote (RFQ). But you can, and should, request a specific fiber supplier that offers high-quality products and technical support.

When specifying optical fiber, *the first step* is to select your fiber supplier. This is important, because not all fiber suppliers have the same reputation for quality and service. And not all fiber suppliers use the same manufacturing process, a key factor in obtaining consistent fiber geometry and optical performance. For example, Corning uses an outside vapor deposition process (OVD) while most other suppliers use a modified core vapor deposition (MCVD) process.

The second step is to determine the fiber type that meets the required system bandwidth and standards requirements. Worst-case bandwidth is determined based on worst-case link lengths and protocol speeds. For example, if the worst-case protocol is Gigabit Ethernet (1000Base-SX or LX) at a 500 meter link length, then 50 µm fiber would be the best choice for an “SX” solution and 50 µm or 62.5 µm can be used for “LX” solutions. This result is based on the fact that the Gigabit Ethernet standard specifies both 50 µm and 62.5 µm for 500 meter “LX” applications and only 50 µm fiber for 500 meter “SX” applications. This finding is further confirmed by finding that gigabit speeds (in Figure 2) require a bandwidth of greater than 400 MHz•km. And since both fibers have 500 MHz•km in the “LX” operating window, either can be used. 50 µm has 500 MHz•km in the “SX” window which also allows it to be used with 850 nm sources.

The third step is to determine other fiber requirements such as attenuation or special lengths.

The final step is to complete a detailed RFQ specification to ensure that you receive exactly what your system needs.

In summary, the fiber selection checklist is:

- ☑1. Choose a reputable fiber & cable supplier.
- ☑2. Choose the fiber type:
 - a. Determine worst-case link lengths.
 - b. Determine current and anticipated protocol speeds for this cabling system.
 - c. Determine worst-case bandwidth requirements (based on 2a and 2b, and also confirm this finding with standards specifications).
 - d. Choose the fiber type that exceeds all anticipated BW requirements of 2c.
- ☑3. Determine any special fiber requirements such as attenuation or special lengths.
- ☑4. Clearly specify fiber supplier, fiber type, and fiber attributes in RFQ.

The following are examples of RFQs for Corning® 50/125 and 62.5/125 multimode fiber as well as Corning®SMF-28™ single-mode fiber.

- **Fiber type: Corning® 50/125 Multimode Optical Fiber**
Core diameter: 50.0 ± 3.0 μm
Cladding diameter: 125.0 ± 2.0 μm
Coating: CPC6
- **Chromatic dispersion**
Minimum zero dispersion wavelength: 1297 nm
Maximum zero dispersion wavelength: 1316 nm
Maximum zero dispersion slope: 0.101 ps/(nm²·km)
- **Bandwidth**
850 nm ≥ 500 MHz·km
1300 nm ≥ 500 MHz·km
- **Core/cladding non-circularity**
Core: ≤ 5%
Cladding: < 2.0%
- **Attenuation**
850 nm ≤ 2.5 dB
1300 nm ≤ 0.8 dB

The attenuation at 1380 nm shall not exceed the attenuation at 1300 nm by more than 3.0 dB/km.
- **Fiber shall be manufactured by the outside vapor deposition (OVD) process.**
- **Supplier shall certify identity of the fiber manufacturer for all fiber used in the specified cable and, upon request, supply fiber ID numbers to ensure traceability.**

- **Fiber type: Corning® 62.5/125 Multimode Optical Fiber**
Core diameter: 62.5 ± 3.0 μm
Cladding diameter: 125.0 ± 2.0 μm
Coating: CPC6
- **Chromatic dispersion**
Minimum zero dispersion wavelength: 1332 nm
Maximum zero dispersion wavelength: 1354 nm
Maximum zero dispersion slope: 0.097 ps/(nm²·km)
- **Bandwidth**
850 nm ≥ 160 MHz·km
1300 nm ≥ 500 MHz·km
- **Core/cladding non-circularity**
Core: ≤ 5%
Cladding: < 2.0%
- **Attenuation**
850 nm ≤ 3.0 dB
1300 nm ≤ 0.7 dB

The attenuation at 1380 nm shall not exceed the attenuation at 1300 nm by more than 1.0 dB/km.
- **Fiber shall be manufactured by the outside vapor deposition (OVD) process.**
- **Supplier shall certify identity of the fiber manufacturer for all fiber used in the specified cable and, upon request, supply fiber ID numbers to ensure traceability.**

- **Fiber type: Corning™ SMF-28 Single-Mode Optical Fiber**
Cladding diameter: 125 ± 1.0 μm
Coating: CPC6
- **Dispersion**
Zero dispersion wavelength: 1301.5 - 1321.5 nm
Zero dispersion slope: ≤ 0.092 ps/(nm²·km)
- **Cladding non-circularity**
≤ 1.0%
- **Core-clad concentricity**
≤ 0.6 μm
- **Mode-field diameter**
9.30 ± 0.50 μm at 1310 nm
10.50 ± 1.0 μm at 1550 nm
- **Cable cutoff wavelength**
< 1260 nm
- **Attenuation**
0.40 at 1310
0.30 at 1550
Attenuation at 1383 ± 3 nm shall not exceed 2.1 dB/km.
- **Attenuation uniformity**
There shall be no point discontinuity greater than 0.10 dB at either 1310 nm or 1550 nm.
- **Fiber shall be manufactured by the outside vapor deposition (OVD) process.**
- **Supplier shall certify identity of the fiber manufacturer for all fiber used in the specified cable and, upon request, supply fiber ID numbers to ensure traceability.**

Summary

Choosing the right fiber for your application is very important. By first understanding your system requirements, and then selecting the appropriate fiber, you will maximize the value and performance of your cabling system.

In summary, the different fiber choices are outlined below.

Attribute	Units	50 μm	62.5 μm	SMF
Bandwidth - 850 nm	MHz·km	500	160	n/a
Bandwidth - 1300 nm	MHz·km	500	500	n/a
Attenuation - 850 nm	dB	2.5	3.0	n/a
Attenuation - 1300 nm	dB	0.8	0.7	0.4
Bending Radius	mm	30	30	30
Relative System Cost	%	100%	100%	400%

The attributes given above represent common values in the industry. Premium grade fibers having higher performance bandwidth and attenuation properties are also available.