



# **The NETCONNECT Enhanced Category 5 Cabling System**

## **Engineering for Performance**



---

<b>INTRODUCTION</b> .....	<b>3</b>
<b>WHERE DID IT COME FROM?</b> .....	<b>3</b>
<b>ENHANCED CATEGORY 5 PERFORMANCE</b> .....	<b>3</b>
WHAT TO TEST .....	3
<i>The Link</i> .....	4
<i>The Channel</i> .....	4
<i>Don't Forget the Cable Assembly</i> .....	4
<b>PERFORMANCE PARAMETERS</b> .....	<b>5</b>
ATTENUATION .....	5
NEAR END CROSSTALK (NEXT) .....	5
POWER SUM NEXT .....	5
ATTENUATION-TO-CROSSTALK RATIO (ACR) .....	6
FAR END CROSSTALK (FEXT) .....	7
RETURN LOSS .....	7
<b>PROPAGATION DELAY AND DELAY SKEW</b> .....	<b>8</b>
<b>TEST RESULTS</b> .....	<b>9</b>
2-CONNECTOR LINK – 110CONNECT OUTLET/PATCH PANEL .....	12
3-CONNECTOR LINK – 110CONNECT PATCH PANEL .....	13
3-CONNECTOR LINK – 110CONNECT XC .....	14
2-CONNECTOR LINK – MULTI-USER OUTLET/PATCH PANEL .....	15
2-CONNECTOR LINK – MULTI-USER OUTLET/110CONNECT XC .....	16
2-CONNECTOR CHANNEL – 110CONNECT OUTLET/PATCH PANEL .....	17
4-CONNECTOR CHANNEL – CONSOLIDATION POINT/PATCH PANELS .....	18
4-CONNECTOR CHANNEL – CONSOLIDATION POINT/110CONNECT XC .....	19
3-CONNECTOR CHANNEL – MULTI-USER OUTLET/PATCH PANELS .....	20
3-CONNECTOR CHANNEL – MULTI-USER OUTLET/110CONNECT XC .....	21
PERFORMANCE MARGINS .....	22
<b>SUMMARY</b> .....	<b>22</b>

---

## Introduction

Choosing a cabling system has never seemed more complicated. Just as most of the issues concerning Category 5 have been resolved, along come standards proposals for Enhanced Category 5, Category 6 and Category 7; even proprietary classification schemes for cabling performance. Just when we were getting comfortable with the concept of implementing 100 Mbps data rates on twisted pair cable, along comes the possibility of achieving one gigabit per second over copper cable. It's enough to boggle the mind.

This paper addresses the AMP NETCONNECT Enhanced Category 5 Cabling System. We'll look at what makes Enhanced Category 5 "enhanced", how this system compares to the standard for Category 5e, and why you should consider specifying Enhanced Category 5 as the minimum cabling system of choice for your business. The AMP NETCONNECT Enhanced Category 5 System is the highest performance Cat 5e system in the industry; exceeding all specifications for Category 5e and 1000BASE-T.

## Where Did It Come From?

What has driven the need to standardize Enhanced Category 5 has been the work done by the IEEE (Institute of Electrical and Electronic Engineers) to implement Gigabit Ethernet on Category 5 cable. 1000BASE-T is radically different from preceding networks in the way that it is transmitted over the cable. Because of that, the IEEE asked the TIA to quantify some additional parameters for Category 5 components and systems that were not originally specified.

Not surprisingly, Gigabit Ethernet pushes the limits and may even exceed the performance capabilities of some installed Category 5 cabling systems. In fact, it may not be possible to exercise all of the allowed options for cabling architectures and still support 1000BASE-T on legacy Cat 5 cabling. This is where Enhanced Category 5 comes in. The TIA has defined performance criteria to establish a standard for Enhanced Category 5 (or Category 5e) that will meet and exceed the requirements of 1000BASE-T systems and address the needs of 4-pair networking applications. And it just so happens that Enhanced Category 5 provides that extra performance headroom required to support Gigabit Ethernet and still take advantage of all of the standard cabling system architectures defined by the TIA. Enhanced Category 5 even provides additional performance headroom to make 10BASE-T and 100BASE-T networks more robust and reliable. Enhanced Category 5 is also now the minimum performance for data cabling required by TIA/EIA-568-B.2.

## Enhanced Category 5 Performance

With the advent of Gigabit Ethernet, the testing of cabling systems has become much more complicated than it was previously. Earlier networks, such as 10BASE-T, token ring, 100BASE-T and even 155 Mbps ATM only use two pairs out of a 4-pair cable; one pair to transmit and one pair to receive. Gigabit Ethernet, on the other hand, transmits *and* receives on all four pairs simultaneously. Because of this, we need to know about additional performance characteristics of the cabling system that were not of interest before.

### ***What to Test***

Before we look at all of these performance characteristics, let's examine what it is that we actually test. The document that defines enhanced Cat 5 performance is TIA/EIA-568-B, "Commercial Building Telecommunications Cabling Standard". There are three sets of specifications in this document: component (cable, patch cords and connecting hardware), link and channel. Component performance specifications are necessary in order for manufacturers to ensure the consistency and quality of their products. Component characteristics, however, don't tell the whole story. The NETCONNECT Enhanced Category 5 System has been engineered as a system, to provide superior performance to multi-vendor, mix-and-match systems. What matters at the bottom line is the performance of the entire installed cabling system, from end to end. In order to ensure that you're getting the best performance for your money; be sure to compare the performance you can expect from the entire cabling system, not just the components. To qualify the system, we need to look at link and channel performance.

---

## *The Link*

The link is the portion of the cabling system that is installed and verified by the cabling contractor. It consists of the work area outlet, the horizontal distribution cable and the horizontal cable termination hardware in the telecommunications closet.

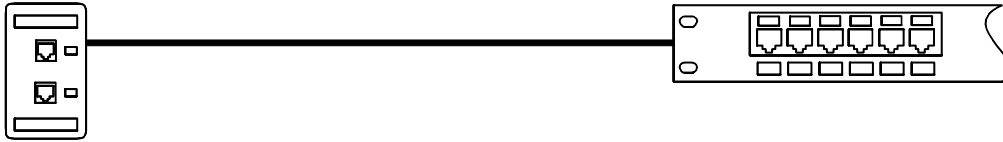
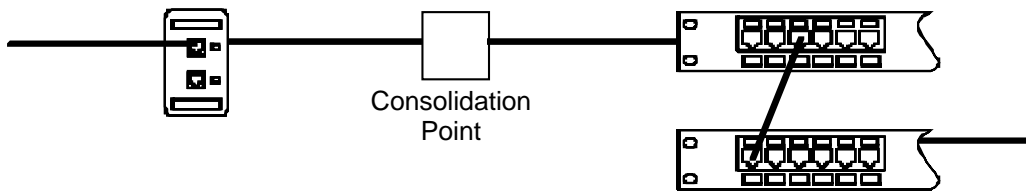

**Figure 1 – The Link**

The link is what the cabling contractor will typically test and certify to Category 5e. The only problem with focussing on link performance characteristics is that, while they tend to look better than channel characteristics, they are not indicative of the performance of the total installed system. For that, we need to look at the channel.

## *The Channel*

The channel represents the entire installed horizontal cabling system – everything between the network interface card in the PC and the LAN electronics in the telecommunications closet (except the equipment connectors). The channel includes the patch cord at the PC, the work area outlet, the horizontal distribution cable, a consolidation point (used for zone distribution), the horizontal termination hardware in the closet, another patch cord, equipment termination hardware and equipment cabling.



**Figure 2 – The Channel**

The channel is what your network electronics see. And as you can tell, a full-blown channel can contain more components than a link. This is the main concern with implementing Gigabit Ethernet over standard Category 5 cabling. It is anticipated that only two-connector Category 5 channels may comply with the requirements for Gigabit Ethernet (and even then additional testing is strongly recommended). In order to ensure compliance with the requirements of 1000BASE-T, while still taking full advantage of the flexibility offered by standard cabling system architectures, it will be necessary to upgrade to Enhanced Category 5.

The AMP NETCONNECT Enhanced Category 5 System has been fully verified by the AMP Americas Regional Laboratory and ETL to comply with the TIA Category 5e performance requirements, at the link level and in a maximum 4-connector channel configuration.

## *Don't Forget the Cable Assembly*

Not only is channel performance the most important measure of a cabling system; the cable assemblies that differentiate the channel from the link are actually the most critical elements of the entire cabling system. That's right, the closer a cabling component is to a network device, the more its performance affects that device. So low quality Category 5 patch cables, which are not engineered and verified with the system, may bring an otherwise sound cabling system to its knees. The above channel test results were obtained using the AMP NETCONNECT Enhanced Category 5 cable assemblies. The enhanced cable assemblies not only provide superior performance but also more

---

consistent, controlled performance than standard assemblies. It is this consistent performance that is the mark of an well-engineered system.

## Performance Parameters

As stated earlier, Category 5e performance testing involves measuring several parameters, many of which were not originally specified for Category 5. These additional parameters are primarily of interest for engineers designing network equipment utilizing 4-pair transmission techniques such as those used in 1000BASE-T. The original Category 5 system parameters are attenuation and near end crosstalk (NEXT). The new parameters specified are: power sum NEXT, far end crosstalk, power sum far end crosstalk, return loss, propagation delay and delay skew. Before we get to the test results, let's take a look at what all of these parameters mean.

### Attenuation

Attenuation is the loss of signal power along the length of a cable, as shown in Figure 3. Attenuation is directly related to the length of the cable and increases as the signal frequency increases. Attenuation measurements are also expressed in decibels, indicating the ratio of the strength of the original transmitted signal to the strength of the received signal.

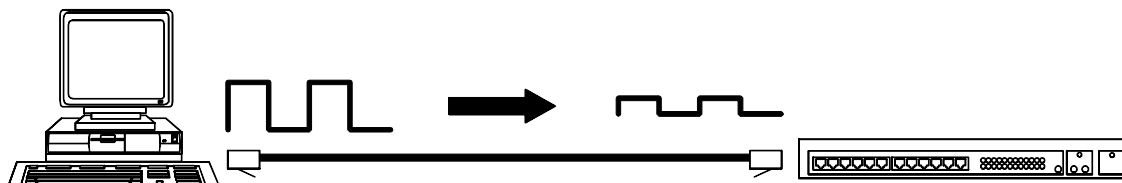

Figure 3 – Attenuation

### Near End Crosstalk (NEXT)

NEXT is perhaps the most important measure used in evaluating performance. A high-speed LAN device may transmit and receive simultaneously. NEXT is the unwanted signal coupling between the transmit pair and receive pair, which adversely affects the quality of the received signal (Figure 4). NEXT measurements are expressed in decibels (dB), which indicate the ratio between the transmit signal and the crosstalk. You may see charts which show NEXT (expressed as negative numbers) or NEXT *loss* (expressed as positive numbers). In either case, the *larger* the number, the *lower* the crosstalk (e.g., 40 dB is better than 30 dB and -40 dB is better than -30 dB).

### Power Sum NEXT

Standard NEXT measurements (pair-to-pair) reflect the common application of one device using one pair to transmit and one pair to receive. That's fine for 10BASE-T and token ring, even 100BASE-T and 155 Mbps ATM. However, faster LANs, such as 1000BASE-T, will utilize all four pairs for transmit and receive. Using more than one pair in a channel for transmission increases the crosstalk level in the channel (Figure 4). The existing 4-pair Category 5 requirements do not take this into consideration. *Power sum* is a mathematical process that combines the NEXT generated from multiple transmit pairs. The sophisticated digital signal processing used by 1000BASE-T to help compensate for near end crosstalk is only so effective. The increase in NEXT and PSNEXT performance represented by Category 5e provides the extra headroom required ensuring gigabit operation even in a worst-case, four-conductor channel.

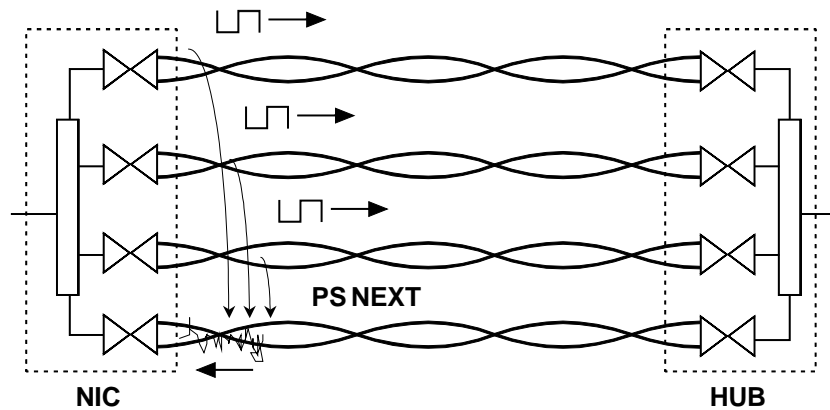

Figure 4 – Near End Crosstalk

### Attenuation-to-crosstalk Ratio (ACR)

The attenuation-to-crosstalk ratio (ACR) is the difference between NEXT and attenuation measurements at a given frequency. While not a requirement of the TIA/EIA-568-B standard, ACR is still a useful performance value as it expresses the relationship between the signal level at the device and the noise level generated from crosstalk. In fact, ACR is essentially the only measurable aspect of the system's signal-to-noise ratio (SNR), which is the determining factor in network performance. Since it encompasses both attenuation and crosstalk, the ACR is the true indicator of performance headroom. Power sum ACR, like power sum NEXT, indicates the performance of the system in applications where there is more than one pair transmitting at a time. It is interesting to note that current LAN electronics require about an 8 dB ACR to function. For a Cat 5e system, this happens around 75 MHz (it's the sophistication of the encoding scheme that makes gigabit transmission possible within this frequency bandwidth). This fact questions the validity of the current industry practice of testing components and systems at frequencies several times higher than their usable bandwidth.

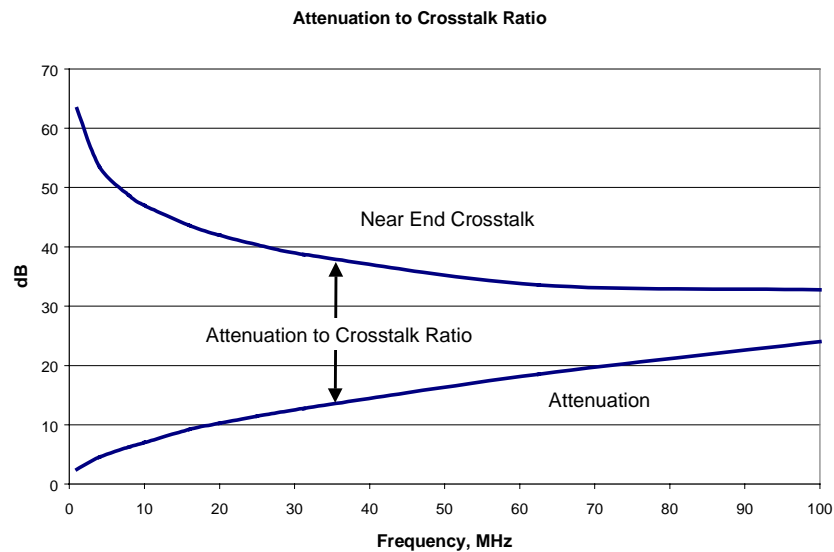

Figure 5 – Attenuation to Crosstalk Ratio

### Far End Crosstalk (FEXT)

One of the unique aspects of the 1000BASE-T transmission scheme is that all four-cable pairs incorporate bi-directional transmission, that is, each pair transmits and receives simultaneously. Unlike two-pair applications (such as 10BASE-T and 100BASE-T), this four-pair transmission creates a need to specify the allowable far end crosstalk of the cabling system. Noise coupled onto pairs at one end of the system travels through the cable and may interfere with reception at the other end.

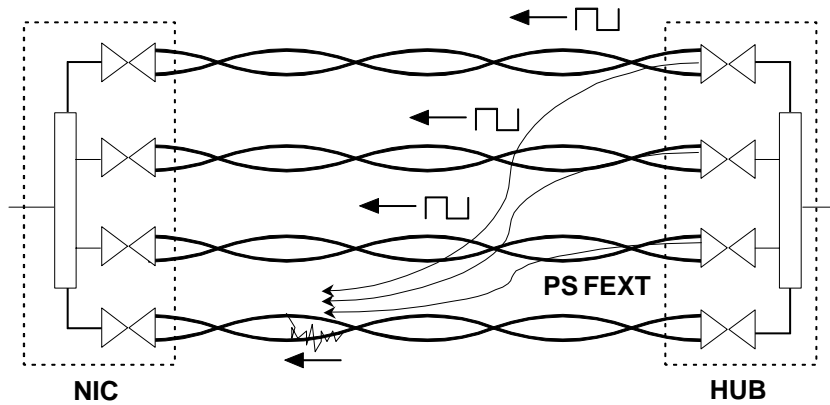

Figure 6 – Far End Crosstalk

The measurement procedure takes into account the attenuation of the cabling system and is referred to as equal level far end crosstalk (ELFEXT). Again, power sum ELFEXT takes into consideration the additional noise generated by multiple transmit pairs.

### Return Loss

Any time a signal hits an impedance mismatch in the cabling system, some of the signal is reflected back toward the transmitter like an echo. Impedance mismatches can be caused by patch cords, connecting hardware and changes in the cable geometry (such as kinks). Return loss is a measure of how much of the signal is reflected. Signal reflections are not much of a problem in two-pair systems. They represent more of a problem in 1000BASE-T since the transmitters also receive.

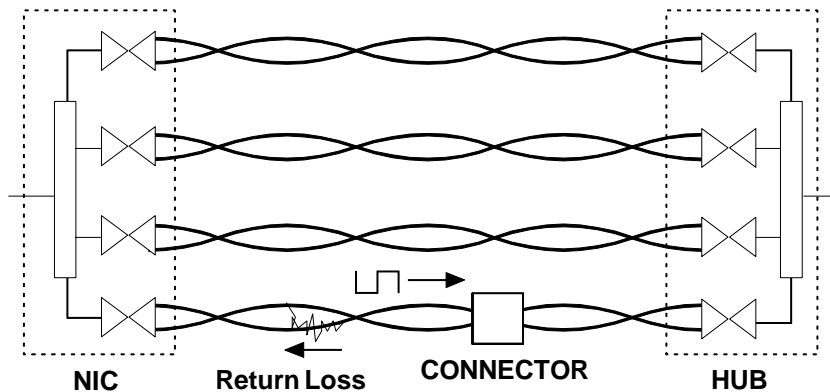

Figure 7 – Return Loss

# Propagation Delay and Delay Skew

Propagation delay is simply the time it takes for a signal to travel from one end of the system to the other. Propagation delay has always been specified for cable and is now specified for link and channel. Delay skew is the difference between the fastest and slowest pairs in the cable, link or channel. It is important for gigabit transmission since the data is split across the four cable pairs and must be "re-assembled" at the other end.

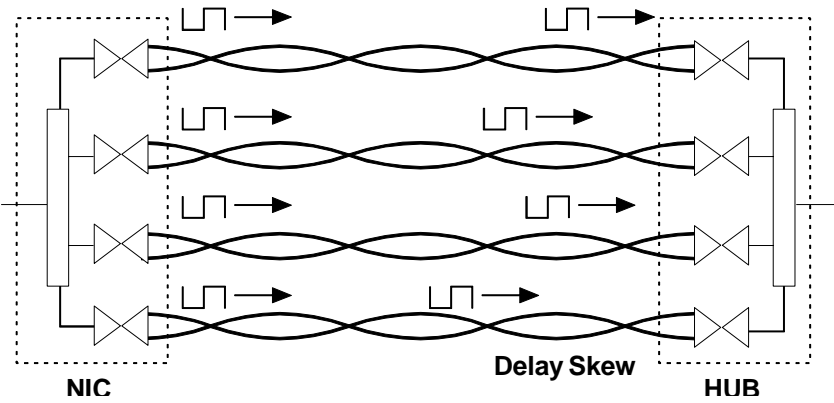

Figure 8 – Delay Skew

## Test Results

Following are the results of the most recent Category 5e testing performed on the AMP NETCONNECT Enhanced Category 5 System by the AMP Americas Regional Laboratory (ARL). The Americas Regional Lab functions as an independent test facility within AMP. Each AMP manufacturing division must submit its products to ARL on a recurring basis for testing to the product design specifications.

The following tests were performed in October/November, 1998 on samples randomly picked from production. The testing was performed on the following cabling system configurations:

### **2-Connector Link with 110Connect Outlet and Patch Panel –**

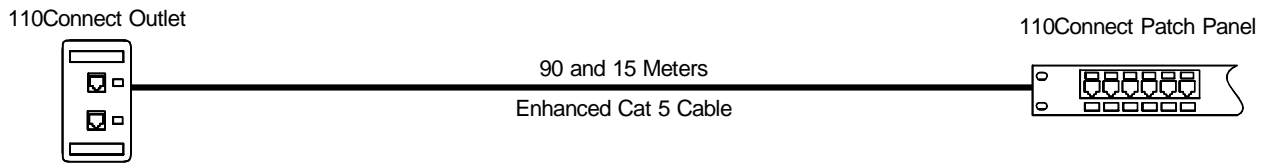

### **3-Connector Link with Consolidation Point and 110Connect Patch Panel –**

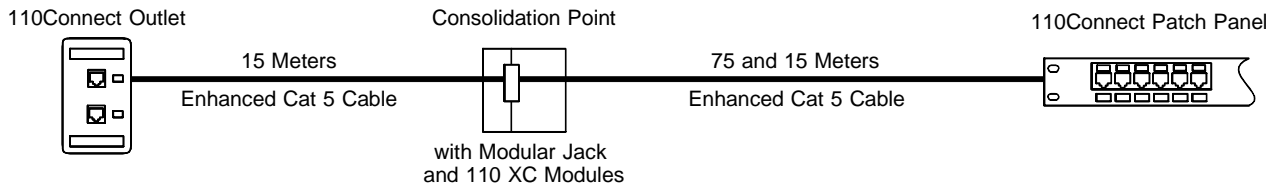

### **3-Connector Link with Consolidation Point and 110Connect XC –**

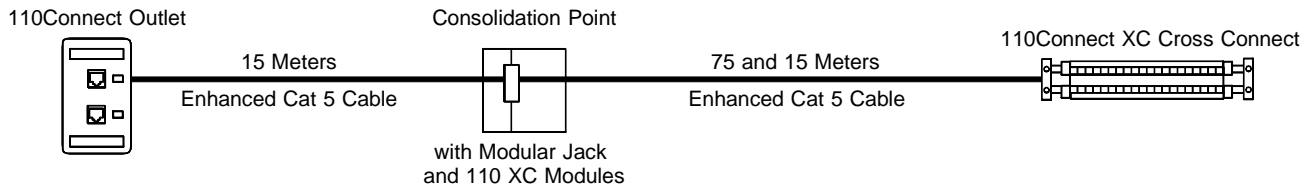

### **2-Connector Link with Multi-user Outlet and 110Connect Patch Panel –**

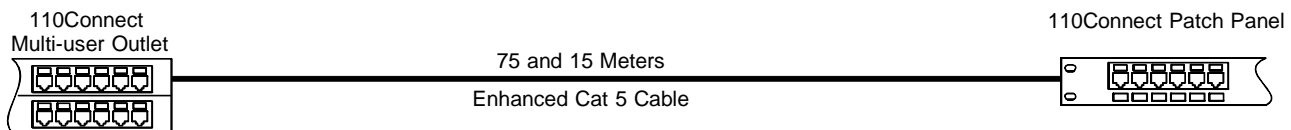

**2-Connector Link with Multi-user Outlet and 110Connect XC –**

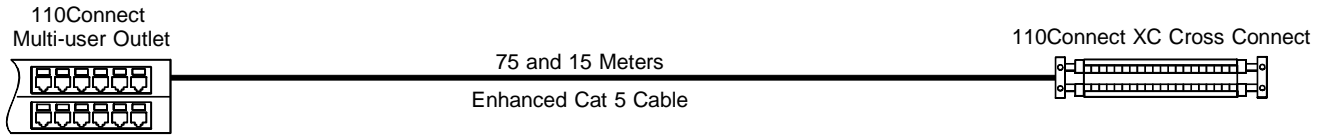

**2-Connector Channel with 110Connect Outlet and Patch Panel**

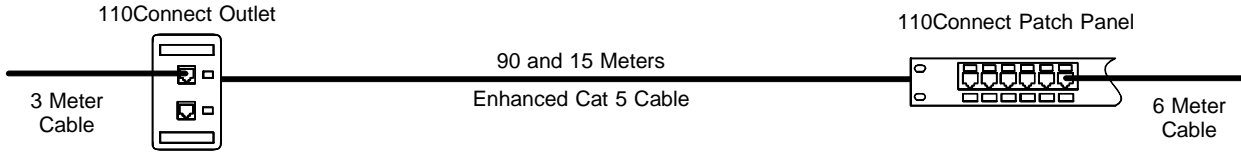

**4-Connector Channel with Consolidation Point and 110Connect Patch Panels –**

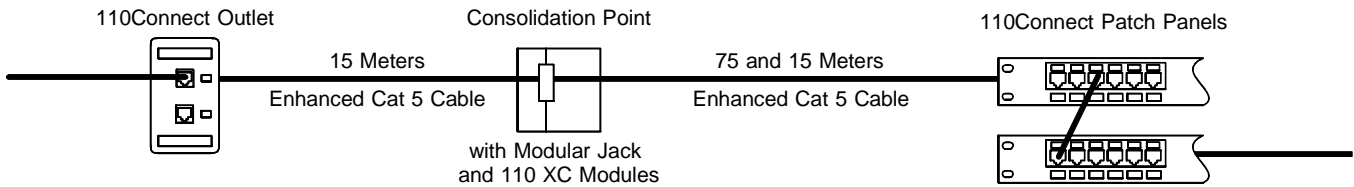

**4-Connector Channel with Consolidation Point and 110Connect XC –**

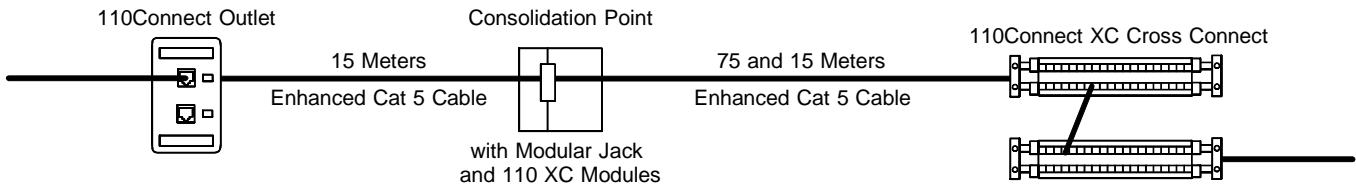

**3-Connector Channel with Multi-user Outlet and 110Connect Patch Panels –**

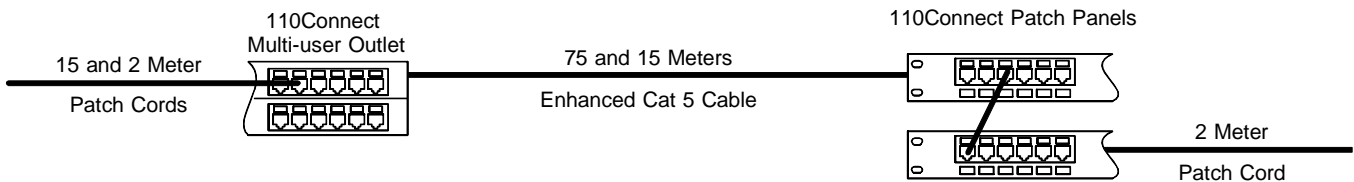

**3-Connector Channel with Multi-user Outlet and 110Connect XC –**

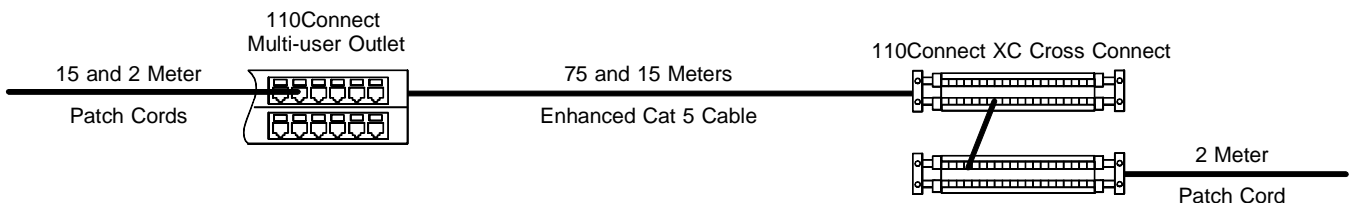

---

Note that each configuration not only includes full-length version but also a short version (15 meters) to ensure the absence of any "short link resonance" problems. Each configuration was tested three times using three different sets of products. All testing was performed bi-directionally, in accordance with all TIA/EIA-568-B requirements using a Hewlett-Packard 8751A network analyzer. The test results shown below are derived by taking the worst-case performance from each of the systems at each of 400 frequency points tested. Summaries are provided which compare the results of each test with the Category 5e requirements. ETL/Semko, a recognized independent test laboratory in the industry, has also tested and verified that the AMP NETCONNECT Enhanced Category 5 system exceeds the requirements of TIA/EIA-568-B Category 5e. The test results of the "4-Connector Channel with Consolidation Point and 110Connect Patch Panels", shown on page 18 are the worst-case results obtained by ETL/Semko in May 2001. At the same time, ETL also subjected the AMP NETCONNECT Enhanced Category 5 System to active testing for 1000BASE-T bit error rate. Over **3.9 trillion** bytes of data were transmitted through the system, with **NO** errors.

## 2-Connector Link – 110Connect Outlet/Patch Panel

110Connect Outlet

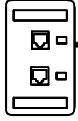

90 and 15 Meters  
Enhanced Cat 5 Cable

110Connect Patch Panel



Frequency, MHz	Attenuation, dB		Return Loss, dB		NEXT, dB		PS NEXT, dB	
	Spec	AMP	Spec	AMP	Spec	AMP	Spec	AMP
1	2.1	2.0	17.0	23.4	60.0	77.0	57.0	74.3
4	4.0	3.9	17.0	22.1	54.8	64.3	52.0	61.8
8	5.7	5.6	17.0	21.6	50.0	61.1	47.1	58.0
10	6.3	6.2	17.0	22.9	48.5	54.5	45.6	52.4
16	8.2	7.9	17.0	23.4	45.2	52.5	42.2	51.3
20	9.2	8.9	17.0	22.0	43.7	55.7	40.7	53.2
25	10.3	10.0	16.3	22.0	42.1	53.6	39.1	51.2
31.25	11.5	11.1	15.6	25.7	40.6	51.4	37.5	48.9
62.5	16.7	16.0	13.5	21.0	35.7	43.2	32.6	41.6
100	21.6	20.5	12.1	14.9	32.3	39.8	29.3	37.6

Frequency, MHz	ELFEXT, dB		PS ELFEXT, dB		ACR, dB		PS ACR, dB	
	Spec	AMP	Spec	AMP	Derived Limit	AMP	Derived Limit	AMP
1	58.0	73.4	55.0	74.1	57.9	76.0	54.9	72.4
4	48.0	61.7	45.0	62.9	50.8	62.0	48.0	58.5
8	41.9	56.1	38.9	57.6	44.3	55.5	41.4	52.0
10	40.0	54.4	37.0	55.4	42.2	48.3	39.3	46.2
16	35.9	51.2	32.9	51.7	37.0	44.6	34.0	43.4
20	34.0	48.7	31.0	50.0	34.5	46.6	32.5	44.6
25	32.0	46.7	29.0	48.1	31.8	44.1	28.8	41.4
31.25	30.1	45.9	27.1	45.7	29.1	39.7	26.0	37.8
62.5	24.1	40.7	21.1	39.6	19.0	29.9	15.9	27.1
100	20.0	37.8	17.0	37.0	10.7	18.4	7.7	17.0

### 3-Connector Link – 110Connect Patch Panel

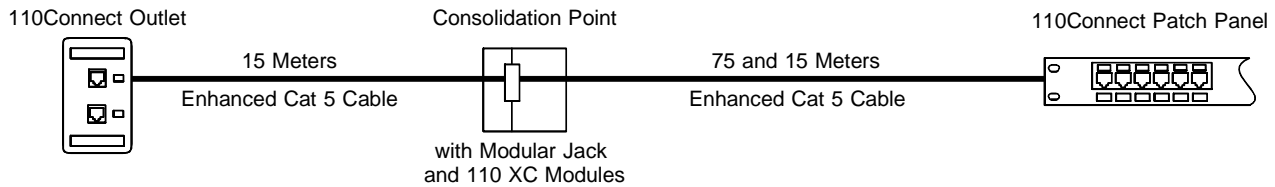

Frequency, MHz	Attenuation, dB		Return Loss, dB		NEXT, dB		PS NEXT, dB	
	Spec	AMP	Spec	AMP	Spec	AMP	Spec	AMP
1	2.1	2.0	17.0	18.9	60.0	72.0	57.0	70.5
4	4.0	3.9	17.0	20.3	54.8	60.3	52.0	57.8
8	5.7	5.5	17.0	21.0	50.0	55.1	47.1	54.0
10	6.3	6.2	17.0	21.2	48.5	55.5	45.6	53.1
16	8.2	7.9	17.0	21.5	45.2	51.9	42.2	49.7
20	9.2	8.8	17.0	23.1	43.7	45.9	40.7	44.8
25	10.3	9.9	16.3	20.9	42.1	44.1	39.1	43.5
31.25	11.5	11.1	15.6	19.2	40.6	43.1	37.5	41.7
62.5	16.7	15.9	13.5	19.4	35.7	37.9	32.6	36.2
100	21.6	20.4	12.1	17.0	32.3	35.7	29.3	34.7

Frequency, MHz	ELFEXT, dB		PS ELFEXT, dB		ACR, dB		PS ACR, dB	
	Spec	AMP	Spec	AMP	Derived Limit	AMP	Derived Limit	AMP
1	58.0	69.6	55.0	67.0	57.9	70.0	54.9	68.6
4	48.0	57.8	45.0	54.9	50.8	57.8	48.0	55.1
8	41.9	52.2	38.9	49.1	44.3	52.1	41.4	49.0
10	40.0	50.1	37.0	47.1	42.2	49.7	39.3	47.3
16	35.9	46.5	32.9	43.8	37.0	45.4	34.0	42.4
20	34.0	44.9	31.0	41.6	34.5	42.6	32.5	40.0
25	32.0	43.4	29.0	40.1	31.8	40.6	28.8	39.4
31.25	30.1	41.6	27.1	38.3	29.1	39.2	26.0	37.4
62.5	24.1	36.3	21.1	33.6	19.0	25.4	15.9	24.0
100	20.0	31.0	17.0	28.0	10.7	15.8	7.7	14.9

### 3-Connector Link – 110Connect XC

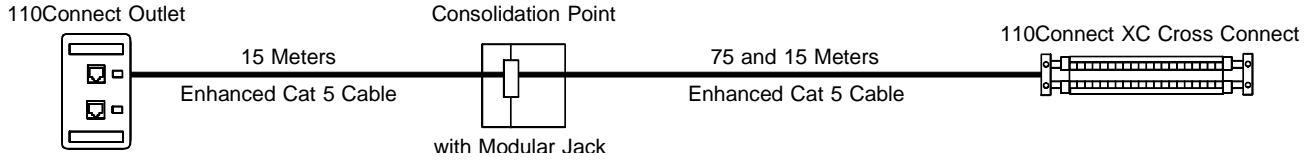

Frequency, MHz	Attenuation, dB		Return Loss, dB		NEXT, dB		PS NEXT, dB	
	Spec	AMP	Spec	AMP	Spec	AMP	Spec	AMP
1	2.1	2.0	17.0	18.9	60.0	73.9	57.0	71.9
4	4.0	3.9	17.0	20.6	54.8	61.4	52.0	58.7
8	5.7	5.5	17.0	21.1	50.0	56.3	47.1	53.6
10	6.3	6.2	17.0	19.6	48.5	54.8	45.6	53.3
16	8.2	7.8	17.0	22.1	45.2	51.6	42.2	50.3
20	9.2	8.8	17.0	21.3	43.7	46.3	40.7	44.8
25	10.3	9.9	16.3	18.6	42.1	46.4	39.1	44.2
31.25	11.5	11.1	15.6	19.9	40.6	44.0	37.5	41.9
62.5	16.7	15.9	13.5	18.6	35.7	40.0	32.6	38.0
100	21.6	20.4	12.1	17.3	32.3	33.4	29.3	31.9

Frequency, MHz	ELFEXT, dB		PS ELFEXT, dB		ACR, dB		PS ACR, dB	
	Spec	AMP	Spec	AMP	Derived Limit	AMP	Derived Limit	AMP
1	58.0	71.1	55.0	69.5	57.9	73.1	54.9	70.6
4	48.0	59.1	45.0	57.8	50.8	57.7	48.0	55.1
8	41.9	52.7	38.9	52.1	44.3	50.9	41.4	48.6
10	40.0	50.6	37.0	50.1	42.2	48.6	39.3	47.1
16	35.9	46.2	32.9	45.9	37.0	44.1	34.0	42.8
20	34.0	44.2	31.0	43.9	34.5	39.1	32.5	37.4
25	32.0	43.1	29.0	42.6	31.8	38.9	28.8	36.5
31.25	30.1	41.3	27.1	40.8	29.1	33.5	26.0	31.2
62.5	24.1	34.8	21.1	33.9	19.0	26.1	15.9	24.0
100	20.0	32.2	17.0	30.6	10.7	14.3	7.7	13.5

## 2-Connector Link – Multi-user Outlet/Patch Panel

110Connect  
Multi-user Outlet



75 and 15 Meters  
Enhanced Cat 5 Cable

110Connect Patch Panel



Frequency, MHz	Attenuation, dB		Return Loss, dB		NEXT, dB		PS NEXT, dB	
	Spec	AMP	Spec	AMP	Spec	AMP	Spec	AMP
1	2.1	1.6	17.0	23.4	60.0	75.9	57.0	74.3
4	4.0	3.3	17.0	22.1	54.8	63.2	52.0	61.2
8	5.7	4.6	17.0	21.6	50.0	61.1	47.1	57.4
10	6.3	5.2	17.0	22.9	48.5	54.5	45.6	52.4
16	8.2	6.6	17.0	23.0	45.2	52.5	42.2	51.3
20	9.2	7.4	17.0	22.0	43.7	54.6	40.7	52.8
25	10.3	8.3	16.3	22.0	42.1	53.6	39.1	51.0
31.25	11.5	9.3	15.6	24.2	40.6	51.4	37.5	48.9
62.5	16.7	13.4	13.5	19.4	35.7	43.2	32.6	41.6
100	21.6	17.1	12.1	14.9	32.3	38.3	29.3	37.2

Frequency, MHz	ELFEXT, dB		PS ELFEXT, dB		ACR, dB		PS ACR, dB	
	Spec	AMP	Spec	AMP	Derived Limit	AMP	Derived Limit	AMP
1	58.0	72.6	55.0	71.6	57.9	75.6	54.9	72.7
4	48.0	60.9	45.0	59.8	50.8	62.5	48.0	59.2
8	41.9	55.3	38.9	54.1	44.3	56.5	41.4	52.9
10	40.0	53.6	37.0	52.6	42.2	49.3	39.3	47.2
16	35.9	48.4	32.9	47.5	37.0	45.9	34.0	44.7
20	34.0	47.2	31.0	46.2	34.5	48.1	32.5	46.1
25	32.0	45.5	29.0	44.3	31.8	46.7	28.8	43.0
31.25	30.1	44.5	27.1	43.0	29.1	42.6	26.0	39.7
62.5	24.1	40.0	21.1	37.9	19.0	32.6	15.9	29.8
100	20.0	33.5	17.0	32.1	10.7	21.8	7.7	20.5

## 2-Connector Link – Multi-user Outlet/110Connect XC

110Connect  
Multi-user Outlet

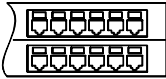

75 and 15 Meters

Enhanced Cat 5 Cable

110Connect XC Cross Connect

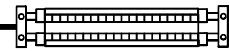

Frequency, MHz	Attenuation, dB		Return Loss, dB		NEXT, dB		PS NEXT, dB	
	Spec	AMP	Spec	AMP	Spec	AMP	Spec	AMP
1	2.1	1.7	17.0	23.2	60.0	75.6	57.0	73.0
4	4.0	3.4	17.0	22.2	54.8	64.4	52.0	61.0
8	5.7	4.7	17.0	20.8	50.0	59.5	47.1	56.3
10	6.3	5.3	17.0	23.1	48.5	55.5	45.6	53.1
16	8.2	6.7	17.0	21.1	45.2	50.7	42.2	49.6
20	9.2	7.4	17.0	21.8	43.7	50.0	40.7	47.8
25	10.3	8.4	16.3	22.3	42.1	46.3	39.1	45.3
31.25	11.5	9.4	15.6	22.4	40.6	45.3	37.5	42.5
62.5	16.7	13.4	13.5	19.1	35.7	39.8	32.6	38.6
100	21.6	17.2	12.1	16.3	32.3	34.0	29.3	33.3

Frequency, MHz	ELFEXT, dB		PS ELFEXT, dB		ACR, dB		PS ACR, dB	
	Spec	AMP	Spec	AMP	Derived Limit	AMP	Derived Limit	AMP
1	58.0	74.7	55.0	71.9	57.9	74.1	54.9	71.4
4	48.0	62.9	45.0	60.5	50.8	61.2	48.0	57.8
8	41.9	57.3	38.9	54.6	44.3	55.0	41.4	51.7
10	40.0	56.2	37.0	53.6	42.2	50.4	39.3	48.0
16	35.9	52.0	32.9	49.0	37.0	45.0	34.0	43.9
20	34.0	50.1	31.0	47.7	34.5	44.4	32.5	41.9
25	32.0	47.8	29.0	45.6	31.8	40.8	28.8	38.3
31.25	30.1	45.6	27.1	43.4	29.1	36.6	26.0	33.7
62.5	24.1	38.7	21.1	37.1	19.0	32.0	15.9	30.5
100	20.0	34.5	17.0	33.0	10.7	20.1	7.7	19.2

## 2-Connector Channel – 110Connect Outlet /Patch Panel

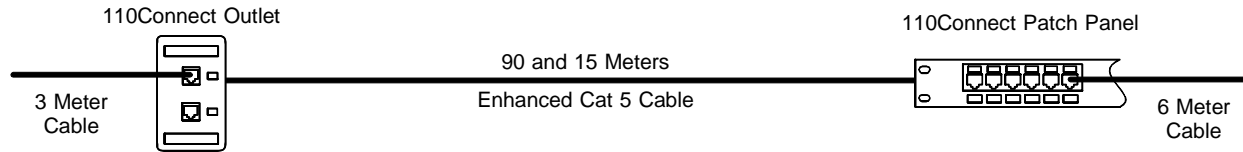

Frequency, MHz	Attenuation, dB		Return Loss, dB		NEXT, dB		PS NEXT, dB	
	Spec	AMP	Spec	AMP	Spec	AMP	Spec	AMP
1	2.5	2.1	17.0	19.4	60.0	75.7	57.0	71.5
4	4.5	4.2	17.0	20.1	53.6	62.7	50.9	59.6
8	6.3	5.9	17.0	23.7	48.6	55.0	45.7	53.3
10	7.0	6.6	17.0	21.8	47.0	53.8	44.1	51.6
16	9.2	8.4	17.0	21.9	43.6	50.4	40.6	48.6
20	10.3	9.4	17.0	22.0	42.0	50.6	39.0	48.6
25	11.4	10.6	16.0	20.8	40.4	51.6	37.3	48.8
31.25	12.8	11.8	15.1	21.9	38.7	49.6	35.7	46.6
62.5	18.5	17.0	12.1	19.9	33.6	38.4	30.6	36.1
100	24.0	21.9	10.0	19.5	30.1	38.2	27.1	35.4

Frequency, MHz	ELFEXT, dB		PS ELFEXT, dB		ACR, dB		PS ACR, dB	
	Spec	AMP	Spec	AMP	Derived Limit	AMP	Derived Limit	AMP
1	57.4	70.2	54.4	67.1	57.5	74.6	54.5	71.7
4	45.3	62.6	42.4	58.1	49.1	61.4	46.4	57.5
8	39.3	56.4	36.3	52.4	42.3	52.8	39.4	50.3
10	37.4	54.2	34.4	50.7	40.0	50.4	37.1	48.1
16	33.3	51.2	30.3	46.5	34.4	45.3	31.4	43.0
20	31.4	49.2	28.4	44.8	31.7	44.6	28.7	42.1
25	29.4	46.9	26.4	43.0	29.0	43.9	25.9	40.3
31.25	27.5	45.3	24.5	41.4	25.9	40.2	22.9	36.7
62.5	21.5	40.7	18.5	36.5	15.1	26.9	12.1	24.2
100	17.4	37.1	14.4	30.0	6.1	18.8	3.1	16.8

## 4-Connector Channel – Consolidation Point/Patch Panels

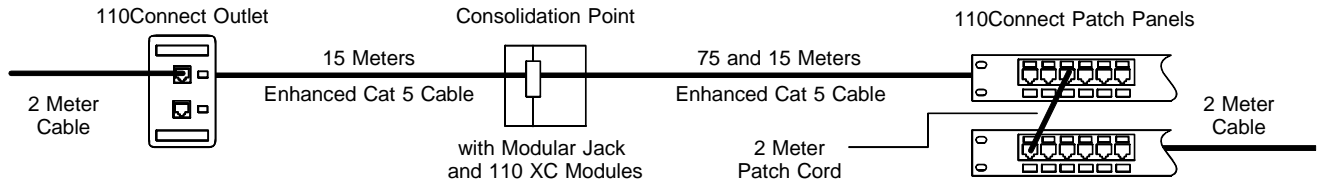

Frequency, MHz	Attenuation, dB		Return Loss, dB		NEXT, dB		PS NEXT, dB	
	Spec	AMP	Spec	AMP	Spec	AMP	Spec	AMP
1	2.5	2.3	17.0	25.6	60.0	70.8	57.0	67.4
4	4.5	3.5	17.0	24.2	53.6	65.7	50.9	62.7
8	6.3	5.4	17.0	22.5	48.6	61.4	45.7	58.3
10	7.0	6.1	17.0	23.3	47.0	57.7	44.1	56.2
16	9.2	8.0	17.0	19.7	43.6	56.1	40.6	52.8
20	10.3	9.0	17.0	20.1	42.0	50.0	39.0	48.5
25	11.4	10.1	16.0	24.1	40.4	48.6	37.3	46.8
31.25	12.8	11.4	15.1	24.1	38.7	48.4	35.7	46.9
62.5	18.5	16.5	12.1	19.3	33.6	43.2	30.6	41.3
100	24.0	21.3	10.0	17.6	30.1	34.2	27.1	33.9

Frequency, MHz	ELFEXT, dB		PS ELFEXT, dB		ACR, dB		PS ACR, dB	
	Spec	AMP	Spec	AMP	Derived Limit	AMP	Derived Limit	AMP
1	57.4	68.4	54.4	66.5	57.5	68.8	54.5	65.4
4	45.3	60.3	42.4	58.1	49.1	62.5	46.4	59.6
8	39.3	52.1	36.3	50.6	42.3	56.4	39.4	53.4
10	37.4	50.3	34.4	48.8	40.0	51.9	37.1	50.4
16	33.3	45.7	30.3	44.2	34.4	48.4	31.4	45.4
20	31.4	44.0	28.4	42.2	31.7	41.5	28.7	40.1
25	29.4	42.0	26.4	40.3	29.0	39.2	25.9	37.4
31.25	27.5	40.2	24.5	38.7	25.9	37.8	22.9	35.6
62.5	21.5	34.4	18.5	31.6	15.1	27.6	12.1	25.8
100	17.4	28.9	14.4	26.9	6.1	13.9	3.1	12.8

## 4-Connector Channel – Consolidation Point/110Connect XC

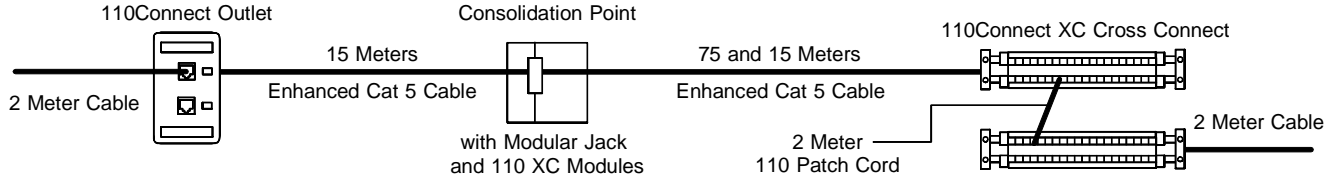

Frequency, MHz	Attenuation, dB		Return Loss, dB		NEXT, dB		PS NEXT, dB	
	Spec	AMP	Spec	AMP	Spec	AMP	Spec	AMP
1	2.5	2.1	17.0	18.7	60.0	70.7	57.0	68.9
4	4.5	4.2	17.0	19.8	53.6	60.7	50.9	58.2
8	6.3	5.9	17.0	20.4	48.6	54.5	45.7	51.7
10	7.0	6.6	17.0	19.6	47.0	54.1	44.1	51.8
16	9.2	8.4	17.0	20.7	43.6	51.6	40.6	50.1
20	10.3	9.4	17.0	20.9	42.0	49.0	39.0	46.4
25	11.4	10.6	16.0	19.3	40.4	47.6	37.3	46.4
31.25	12.8	11.9	15.1	18.9	38.7	48.5	35.7	45.5
62.5	18.5	17.1	12.1	18.5	33.6	39.6	30.6	38.4
100	24.0	22.0	10.0	15.4	30.1	32.3	27.1	30.7

Frequency, MHz	ELFEXT, dB		PS ELFEXT, dB		ACR, dB		PS ACR, dB	
	Spec	AMP	Spec	AMP	Derived Limit	AMP	Derived Limit	AMP
1	57.4	72.1	54.4	70.4	57.5	70.0	54.5	67.4
4	45.3	60.1	42.4	57.8	49.1	56.9	46.4	54.2
8	39.3	54.7	36.3	52.8	42.3	48.7	39.4	46.0
10	37.4	53.0	34.4	50.9	40.0	47.8	37.1	45.5
16	33.3	49.3	30.3	47.1	34.4	43.9	31.4	42.3
20	31.4	47.5	28.4	45.4	31.7	42.8	28.7	39.7
25	29.4	45.6	26.4	42.8	29.0	42.0	25.9	39.7
31.25	27.5	43.4	24.5	40.3	25.9	38.8	22.9	34.2
62.5	21.5	36.3	18.5	34.4	15.1	24.8	12.1	23.0
100	17.4	32.9	14.4	30.3	6.1	12.4	3.1	11.3

### 3-Connector Channel – Multi-user Outlet/Patch Panels

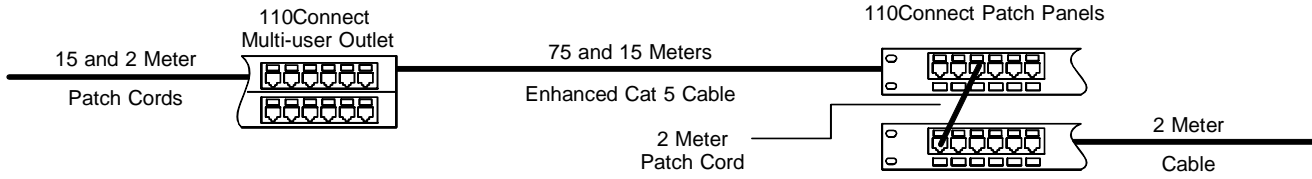

Frequency, MHz	Attenuation, dB		Return Loss, dB		NEXT, dB		PS NEXT, dB	
	Spec	AMP	Spec	AMP	Spec	AMP	Spec	AMP
1	2.5	2.1	17.0	22.4	60.0	75.7	57.0	72.5
4	4.5	4.0	17.0	25.0	53.6	63.5	50.9	60.2
8	6.3	5.7	17.0	21.4	48.6	60.3	45.7	57.1
10	7.0	6.4	17.0	22.3	47.0	59.8	44.1	53.2
16	9.2	8.2	17.0	20.2	43.6	54.6	40.6	52.2
20	10.3	9.2	17.0	21.8	42.0	52.6	39.0	51.2
25	11.4	10.4	16.0	20.0	40.4	50.6	37.3	48.3
31.25	12.8	11.6	15.1	19.8	38.7	50.1	35.7	44.7
62.5	18.5	16.9	12.1	19.7	33.6	42.1	30.6	39.7
100	24.0	22.1	10.0	14.3	30.1	36.3	27.1	35.1

Frequency, MHz	ELFEXT, dB		PS ELFEXT, dB		ACR, dB		PS ACR, dB	
	Spec	AMP	Spec	AMP	Derived Limit	AMP	Derived Limit	AMP
1	57.4	68.5	54.4	66.8	57.5	73.9	54.5	70.7
4	45.3	56.1	42.4	55.5	49.1	62.8	46.4	56.6
8	39.3	52.0	36.3	49.5	42.3	55.1	39.4	51.9
10	37.4	50.4	34.4	47.7	40.0	53.9	37.1	47.5
16	33.3	48.2	30.3	44.0	34.4	46.5	31.4	44.9
20	31.4	46.8	28.4	41.8	31.7	43.6	28.7	42.1
25	29.4	43.9	26.4	40.3	29.0	41.2	25.9	38.9
31.25	27.5	40.6	24.5	38.6	25.9	38.5	22.9	36.4
62.5	21.5	38.0	18.5	34.3	15.1	30.3	12.1	27.4
100	17.4	31.8	14.4	29.9	6.1	14.5	3.1	13.3

### 3-Connector Channel – Multi-user Outlet/110Connect XC

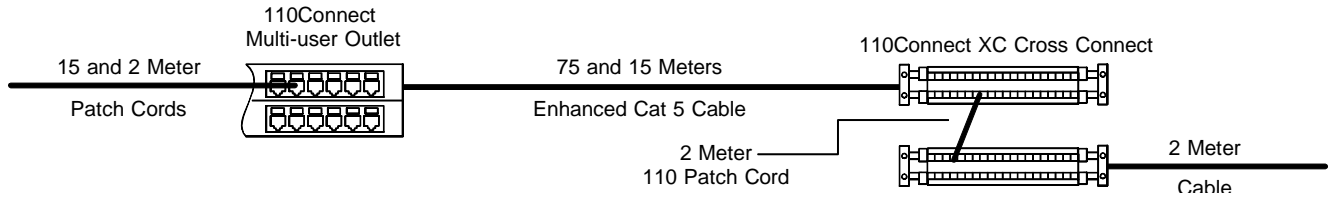

Frequency, MHz	Attenuation, dB		Return Loss, dB		NEXT, dB		PS NEXT, dB	
	Spec	AMP	Spec	AMP	Spec	AMP	Spec	AMP
1	2.5	1.9	17.0	22.3	60.0	72.2	57.0	68.8
4	4.5	3.9	17.0	22.3	53.6	59.4	50.9	57.8
8	6.3	5.7	17.0	20.5	48.6	53.6	45.7	52.1
10	7.0	6.3	17.0	20.6	47.0	54.0	44.1	51.7
16	9.2	8.1	17.0	20.1	43.6	50.7	40.6	49.6
20	10.3	9.0	17.0	22.4	42.0	51.4	39.0	49.3
25	11.4	10.2	16.0	21.9	40.4	50.5	37.3	49.0
31.25	12.8	11.4	15.1	20.7	38.7	50.4	35.7	47.4
62.5	18.5	16.5	12.1	18.1	33.6	41.6	30.6	39.3
100	24.0	21.3	10.0	13.8	30.1	32.5	27.1	31.5

Frequency, MHz	ELFEXT, dB		PS ELFEXT, dB		ACR, dB		PS ACR, dB	
	Spec	AMP	Spec	AMP	Derived Limit	AMP	Derived Limit	AMP
1	57.4	77.2	54.4	73.2	57.5	71.3	54.5	67.0
4	45.3	65.0	42.4	60.8	49.1	57.0	46.4	54.3
8	39.3	59.0	36.3	56.0	42.3	48.6	39.4	46.7
10	37.4	57.2	34.4	53.1	40.0	48.1	37.1	45.5
16	33.3	53.5	30.3	50.0	34.4	43.6	31.4	42.2
20	31.4	51.9	28.4	47.8	31.7	42.7	28.7	40.8
25	29.4	49.8	26.4	46.4	29.0	41.9	25.9	39.7
31.25	27.5	48.0	24.5	44.6	25.9	39.0	22.9	36.0
62.5	21.5	42.7	18.5	38.6	15.1	26.4	12.1	24.5
100	17.4	36.2	14.4	34.2	6.1	14.1	3.1	11.7

## Performance Margins

The table below shows the worst-case performance margin from either end above TIA Category 5e requirements for each system configuration tested at 100 MHz. As the table and the test data indicates, the AMP NETCONNECT Enhanced Category 5 System provides significant performance above the requirements for Category 5e for all (not just selected) performance parameters. The AMP 25-Year System Performance Warranty states that the AMP NETCONNECT Enhanced Category 5 exceeds the performance parameters of the Category 5e specification and the requirements of 1000BASE-T.

	AMP NETCONNECT Enhanced Category 5									
	Performance Margins Above Category 5e Requirements at 100 MHz									
	Links					Channels				
	2-Conn. Outlet/ Patch Panel	3-Conn. CP/ Patch Panel	3-Conn. CP/ 110 XC	2-Conn. MUO/ Patch Panel	2-Conn. MUO/ 110 XC	2-Conn. Outlet/ Patch Panel	4-Conn. CP/ Patch Panel	4-Conn. CP/ 110 XC	3-Conn. MUO/ Patch Panel	3-Conn. MUO/ 110 XC
Attenuation	1.1	1.2	1.3	4.5	4.4	2.1	2.7	2.0	1.9	2.7
Return Loss	2.8	4.9	5.1	2.8	4.2	9.5	7.6	5.4	4.3	3.8
NEXT	7.5	3.4	1.1	6.0	1.7	8.1	4.1	2.2	6.2	2.4
PS NEXT	8.3	5.4	2.6	7.9	4.0	8.3	6.8	3.6	8.0	4.4
ELFEXT	17.8	11.0	12.2	13.5	14.5	19.7	11.5	15.5	14.4	18.8
PS ELFEXT	20	11.0	13.6	15.1	16.0	15.6	12.5	15.9	15.5	19.8
ACR	7.7	5.1	3.6	11.1	9.4	12.7	7.8	6.4	8.4	8.0
PS ACR	9.3	7.3	5.8	12.8	11.6	13.7	9.7	8.2	10.2	8.6

## Summary

The NETCONNECT Enhanced Category 5 Cabling System represents the next step beyond Cat 5 in cabling system performance. AMP has integrated high performance components, patented manufacturing processes and systems engineering into a finely tuned cabling system that offers performance generously exceeding the requirements of TIA/EIA-568-B. AMP components are engineered to operate together on a system level. Components alone do not ensure adequate system-level performance. Single-manufacturer solutions will typically provide the highest performance. The test results reported here show that the NETCONNECT Enhanced Category 5 System offers the headroom required to support both Gigabit Ethernet and still offer the flexibility of today's most demanding cabling system architectures.